

June 2020

Description

The TMZ PC-Programmable MODBUS Temperature Transmitter and Signal Converter accepts a single or dual direct signal inputs from a wide array of sensors and analog devices:

RTD • Thermocouple • Current • Voltage

Millivolt • Ohms • Resistance • Potentiometer

Analog-to-MODBUS Conversion

The 4-wire (line/mains-powered) TMZ converts the inputs to the standard MODBUS RTU (RS-485) communication protocol ready for direct interface with MODBUS-based monitoring and control systems.

Save Wiring and Installation Costs

When monitoring points are dispersed, or in small clusters, the TMZ is the ideal solution for collecting and concentrating them onto a single MODBUS RTU communication link.

Up to 32 TMZs (without repeaters) can be multidropped onto a single low-cost communication link (such as a twisted wire pair). This eliminates the need to run a dedicated wire for each signal, and delivers significant savings on installation, cable, conduit, connection and wire tray costs.



The TMZ is available in a single or dual input model that snaps onto standard DIN-style rails.

Figure 1. Available TMZ models deliver versatile input and output options.

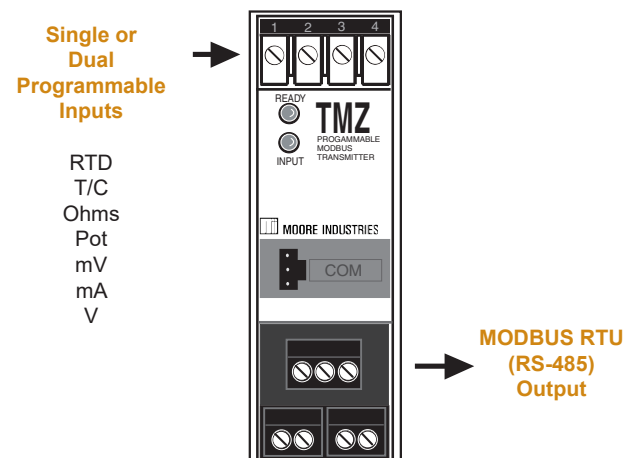

Certifications



CE Conformant – EMC Directive 2014/30/EU – EN 61326

Features

- **20-bit input resolution delivers exceptional digital measurement accuracy.** The TMZ delivers accuracy of $\pm 0.1^{\circ}\text{C}$ ($\pm 0.18^{\circ}\text{F}$) with all platinum RTDs, or $\pm 0.01\%$ of maximum span with current and voltage inputs.
- **Increase density and reduce costs.** The Dual Universal Input (2PRG) model accepts two inputs where each input can be configured for current, voltage, RTD, Thermocouple, mV, Potentiometer or Resistance, doubling your monitoring capability in a single unit.
- **Output error is eliminated.** Since the measurement is delivered to your control system as a digital signal, the output error produced by a traditional analog transmitter is eliminated.
- **PC-programmable with Windows® software.** From a single screen, you can choose, and then view to confirm, all of your application specific operating parameters from a PC.
- **Long-term stability.** Allows up to 5 years between scheduled calibrations.
- **Isolated and RFI/EMI protection.** Delivers superior protection against the effects of ground loops, plant noise, radio frequency and electromagnetic interference.

TMZ

PC-Programmable MODBUS Temperature Transmitter and Signal Converter

Figure 2. Up to 32 TMZs, without repeaters, can be multidropped onto a single MODBUS RTU communication link.

The TMZ can be installed on the same data link with standard MODBUS RTU devices including Moore Industries' NCS NET Concentrator[®] Process Control and Distributed I/O System (shown below).

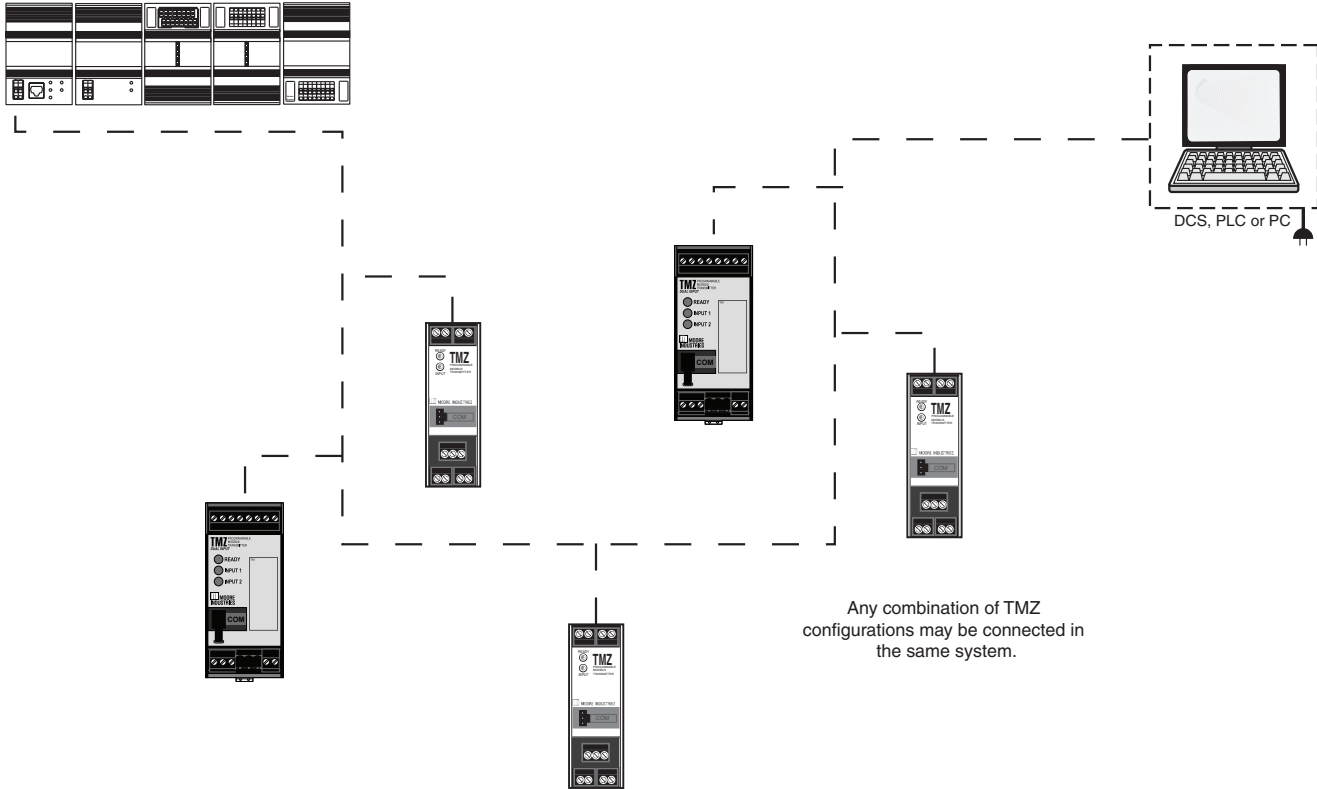

One Window. One Minute. One Setup.

All operating parameters configure quickly and easily using our Intelligent PC Configuration Software. Programmable functions include:

- Input type and measurement range (zero and full scale values)
- Input trimming
- MODBUS parameters
- T/C reference junction compensation (on/off)
- Standard and custom linearization curves

Figure 3. The TMZ programs quickly and easily.

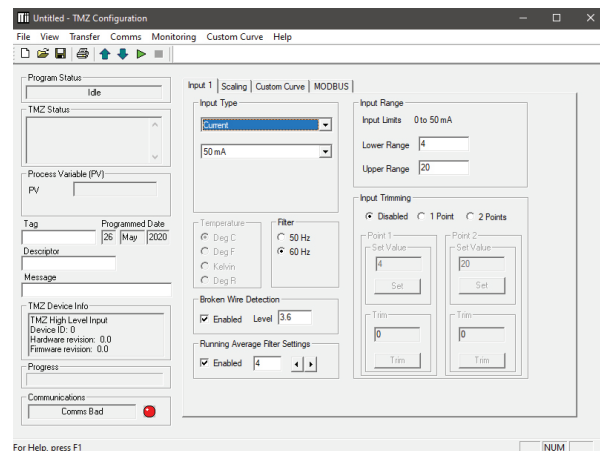

Trim to Specific Curve Segments

The TMZ can be trimmed with two data points within the selected zero and span measurement range. This allows a complete process range to be monitored, while placing measurement emphasis on a critical segment of the range.

In the figure below, the ideal RTD curve is optimized between 20°C and 27°C to match the curve of the sensor used. This provides incredible precision over a limited portion of the span, while measuring the remainder of the span with outstanding accuracy.

Figure 4. The TMZ can be set to measure the segment most critical to the process.

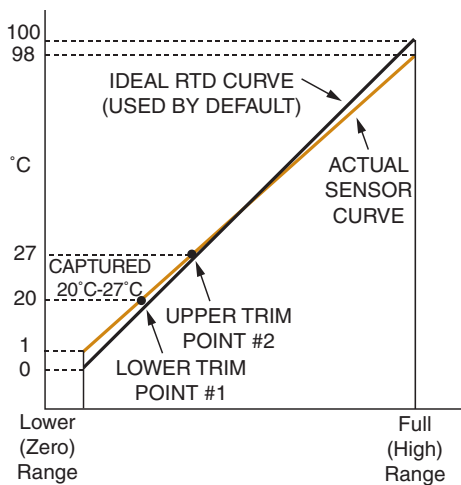

Total Sensor Diagnostics for RTD Inputs

If an RTD input breaks, the user can view plain-English error messages on the PC software that identifies exactly which RTD wire has broken. These specific error messages eliminate the work of removing the sensor or checking all lead wires to diagnose a problem.

Monitor Two Inputs

With the Dual Universal Input 2PRG model data from both inputs is available on the MODBUS output where the host can use the data for averaging, differential or backup/redundancy applications.

Powers a 2-Wire Transmitter

The TMZ (Single Input HLPRG, Dual Universal Input 2PRG) current/voltage input model comes standard with 2-wire transmitter excitation* that provides 24Vdc to power the loop. This saves the cost of specifying and installing an additional instrument power supply.

* 2PRG model powers transmitter on input 1 only

Figure 5. The TMZ provides transmitter excitation to power a 2-wire transmitter.

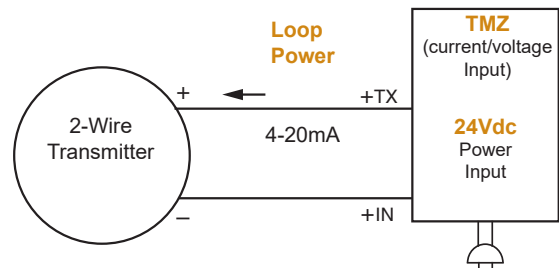

Custom 128-Point Linearization Curves

The ability to plot a custom linearization curve is beneficial when non-linear input signals must be converted to linear output representations. Typical applications include monitoring a non-linear transducer, the level of odd-shaped tanks, and flow meter linearization*.

*Custom curve functionality is not available for 2PRG models.

Figure 6. Custom linearization points can be selected and saved in the TMZ's memory to compensate for non-linear input signals.

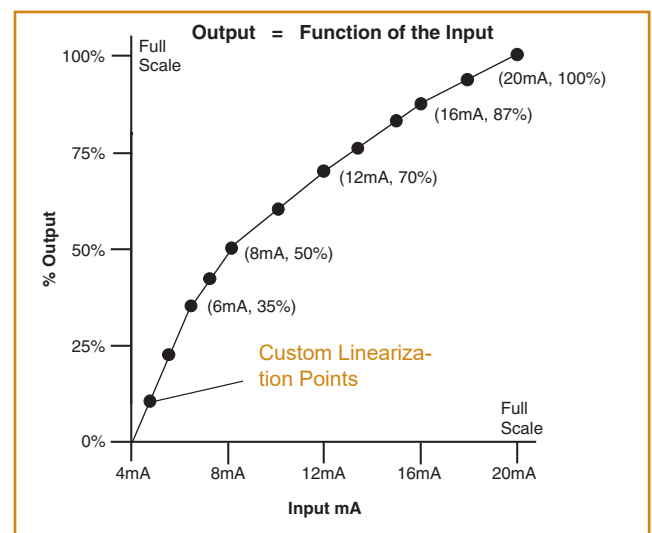

Specifications 2PRG and HLPRG: mA and V Input Model

Performance

Input Accuracy: Current ± 2 microamps; Voltage $\pm 1\text{mV}$
Overall Accuracy: The overall accuracy of the unit is the input accuracy. It includes the combined effects of linearity, hysteresis, repeatability and adjustment resolution.
Stability: See Table 1
Response Time: INPUT UPDATE TIME: 128msec; MODBUS POLLING TIME: Dependent upon how fast and how often a MODBUS master requests data
Isolation: DUAL INPUT AND SINGLE INPUT (WITH -RF) : 500Vrms between case and input; input to MODBUS; power to case and power to MODBUS. 500Vrms between input 1 and input 2 for 2PRG model.
 SINGLE INPUT (NON -RF) : 1000Vrms between case and input. 500Vrms between input to MODBUS and power to MODBUS. 1500Vrms between power and input.
Power Supply: 9-30Vdc
Power Consumption: 1W max
Input Impedance: Current, 20 ohms;

Voltage, 1.1 Mohms
Input Over-Range Protection: Current, $\pm 100\text{mA}$; Voltage, $\pm 30\text{Vdc}$
TX Power Supply: 23.2Vdc $\pm 3\% @ 24\text{mA}$

Communications

Type: Standard MODBUS RTU protocol interface over RS-485 (parameters as specified in U.S. Standard EIA-RS485)
Address Range: Configurable from 1 to 247. Unit will assume a MODBUS address of 1 by default.
Baud Rates: Interface supports the following: 300, 600, 1200, 2400, 4800, 9600, 19.2k and 38.4k
Character Format: One start bit, 8 data bits and one stop bit
Parity: None, even or odd

Indicators

Indicators LED Type: INPUT LED: Dual color Red/Green LED, Red LED indicates input failure
 READY LED: Dual Color Red/Green LED, Green LED indicates unit is operating properly
 2PRG model has 2 INPUT LEDs, one for each input

Ambient Conditions

Operating & Storage Range: -40°C to $+85^{\circ}\text{C}$ (-40°F to $+185^{\circ}\text{F}$)
Relative Humidity: 0-95%, non-condensing
Ambient Temperature Effect: Current, 2 microamps/ $^{\circ}\text{C}$; Voltage, $1\text{mV}/^{\circ}\text{C}$
RFI/EMI Immunity: Tested per IEC61000-4-3 HLPRG UNIT: $10\text{V/m} @ 20\text{-}1000\text{MHz}$, 1kHz AM
 2PRG and HLPRG WITH -RF OPTION: $20\text{V/m} @ 20\text{-}1000\text{MHz}$, 1kHz AM
Noise Rejection: Common mode: $100\text{dB} @ 50/60\text{Hz}$; Normal Mode: Current Input, 100dB typical@ $50\text{mA-p-p} @ 50/60\text{Hz}$; Voltage Input, 100dB typical@ $1\text{Vp-p} @ 50/60\text{Hz}$

Weight

290 g (10.2 oz)
 440g (15.6 oz) 2PRG model

Table 1. Long-Term Stability for HLPRG, 2PRG (mA and V) Input Model

| Stability (% of maximum span) | Input Circuit (Years) | | |
|----------------------------------|--------------------------|------|------|
| | 1 | 3 | 5 |
| Current Inputs | 0.081 | 0.14 | 0.18 |
| Voltage Inputs | 0.093 | 0.16 | 0.21 |

Table 2. Long-Term Stability for TPRG, 2PRG (RTD, T/C, mV, Ohms, Pot) Input Model

| Stability (% of maximum span) | Input Circuit (Years) | | |
|----------------------------------|--------------------------|------|------|
| | 1 | 3 | 5 |
| RTD, Ohm, & Pot Inputs | 0.09 | 0.16 | 0.21 |
| T/C & mV Inputs | 0.08 | 0.14 | 0.18 |

Specifications 2PRG and TPRG: RTD, T/C, mV, Ohms and Pot Input Model

Performance

Input Accuracy:

See Table 5

Overall Accuracy: The overall accuracy of the unit is the input accuracy. It includes the combined effects of linearity, hysteresis, repeatability and adjustment resolution. It does not include ambient temperature effect. For T/C input, add the RJC error.

Reference Junction Compensation Accuracy (T/C Inputs Only): $\pm 0.65^{\circ}\text{C}$

Stability: See Table 2

Response Time: INPUT UPDATE TIME: 128msec; MODBUS POLLING TIME: Dependent upon how fast and how often a MODBUS master requests data

Isolation: DUAL INPUT AND SINGLE INPUT (WITH -RF) : 500Vrms between case and input; input to MODBUS; power to case and power to MODBUS; 500Vrms between input 1 and input 2 for 2PRG model;

SINGLE INPUT (NON -RF) : 1000Vrms between case and input. 500Vrms between input to MODBUS and power to MODBUS. 1500Vrms between power and input.

Power Supply: 9-30Vdc

Power Consumption:

1W maximum

Input Impedance: T/C and mV inputs, 40 Mohms, nominal

Input Over-Range Protection:

$\pm 3\text{Vdc}$ = maximum

Excitation Current (RTD and Ohm Inputs Only): 250 microamps, $\pm 10\%$

Communications

Type: Standard MODBUS RTU protocol interface over RS-485 (parameters as specified in U.S. Standard EIA-RS485)

Address Range: Configurable from 1 to 247. Unit will assume a MODBUS address of 01 by default.

Baud Rates: Interface supports the following: 300, 600, 1200, 2400, 4800, 9600, 19.2k and 38.4k

Character Format: One start bit, 8 data bits and one stop bit

Parity: None, even or odd

Indicators

Indicators LED Type: INPUT LED:

Dual color Red/Green LED, Red LED

indicates input failure READY LED:

Dual Color Red/Green LED, Green LED indicates unit is operating properly 2PRG model has 2 INPUT LEDs, one

for each input

Ambient Conditions

Operating & Storage Range:

-40°C to $+85^{\circ}\text{C}$

(-40°F to $+185^{\circ}\text{F}$)

Effect of Ambient

Temperature on Cold Junction Compensation (T/C Inputs

Only): $\pm 0.005^{\circ}\text{C}$ per $^{\circ}\text{C}$ change of ambient temperature

Relative Humidity:

0-95%, non-condensing

Ambient Temperature Effect:

See Table 4

RFI/EMI Immunity Tested per

IEC61000-4-3 TPRG UNIT:

10V/m@20-1000MHz, 1kHz AM

2PRG and TPRG WITH -RF

OPTION:

20V/m@20-1000MHz, 1kHz AM

Noise Rejection:

Common mode,

100dB@50/60Hz; Normal mode,

refer to Table 3

Weight

290 g (10.2 oz);

440g (15.6 oz) 2PRG model

Table 3. Normal Mode Rejection Ratio Table

| Sensor Type | Max. p-p Voltage Injection for 70dB at 50/60Hz |
|--------------------------------|------------------------------------------------|
| T/C E | 120mV |
| T/C J, K, N, C | 60mV |
| T/C T, R, S, B | 30mV |
| 100 ohm Pt RTD | 120mV |
| 200 ohm Pt RTD | 200mV |
| 300, 400, 500, 1000 ohm Pt RTD | 400mV |
| 1000 ohm Pt RTD | 800mV |
| 120 ohm Ni RTD | 200mV |
| 9.03 ohm Cu RTD | 30mV |
| Resistance 4Kohm/mV 1000mV | 800mV |
| Resistance 2Kohm/mV 500mV | 400mV |
| Resistance 1Kohm/mV 250mV | 200mV |
| Resistance 500ohm/mV 125mV | 100mV |
| Resistance 250ohm/mV 62.5mV | 50mV |
| Resistance 125ohm/mV 31.25mV | 30mV |

Table 4. Ambient Temperature Effect

| Input Type | Accuracy per 1°C (1.8°F) change in Ambient |
|---------------|--------------------------------------------|
| *RTD | 0.0035°C + 0.005% of reading |
| Ohm | 0.002 ohms + 0.005% of reading |
| Thermocouples | |
| Input Type | Accuracy per 1°C (1.8°F) change in Ambient |
| J | 0.00016°C + 0.005% of reading |
| K | 0.0002°C + 0.005% of reading |
| E | 0.00026°C + 0.005% of reading |
| T | 0.0001°C + 0.005% of reading |
| R, S | 0.00075°C + 0.005% of reading |
| B | 0.0038°C + 0.005% of reading |
| N | 0.0003°C + 0.005% of reading |
| C | 0.00043°C + 0.005% of reading |
| mV | 0.5 microvolts + 0.005% of reading |

*Accuracy of Ni672 is 0.002°C

PC-Programmable MODBUS Temperature Transmitter and Signal Converter

Table 5. Accuracy with RTD, Thermocouple, mV, Ohms, and Pot Inputs (Models with TPRG and 2PRG Input)

| Input | Type | α | Ohms | Conformance Range | Input Accuracy/Repeatability | Maximum Range |
|----------------------------|-------------------|--------------------------------|---------------------------------|----------------------------------|------------------------------|------------------------------------|
| RTD (2-, 3-, 4-Wire) | Platinum | 0.003850 | 100 | -200 to 850°C -328 to 1562°F | ±0.1°C (±0.18°F) | -240 to 960°C -400 to 1760°F |
| | | | 200 | | | |
| | | | 300 | | | |
| | | | 400 | | | |
| | | | 500 | | | |
| | | | 1000 | | | |
| | 0.003902 | 100 | -100 to 650°C -148 to 1202°F | | | |
| | | 200 | | | | |
| | | 400 | | | | |
| | | 500 | | | | |
| 1000 | | | | | | |
| 0.003916 | 100 | -200 to 510°C -328 to 950°F | -240 to 580°C -400 to 1076°F | | | |
| Nickel | 0.00672 | 120 | -80 to 320°C -112 to 608°F | -100 to 360°C -148 to 680°F | | |
| Copper | 0.00427 | 9.035 | -50 to 250°C -58 to 482°F | ±1.5°C (±2.7°F) | -65 to 280°C -85 to 536°F | |
| Ohms | Direct Resistance | n/a | 0-4000 | 0-4000 ohms | ±0.4 ohms | 0-4095 ohms |
| | Potentiometer | | 4000 max. | 0-100% | ±0.1% | 0-100% |
| T/C | J | n/a | n/a | -180 to 760°C -292 to 1400°F | ±0.25°C (±0.45°F) | -210 to 770°C -346 to 1418°F |
| | K | n/a | n/a | -150 to 1370°C -238 to 2498°F | ±0.30°C (±0.54°F) | -270 to 1390°C -454 to 2534°F |
| | E | n/a | n/a | -170 to 1000°C -274 to 1832°F | ±0.20°C (±0.36°F) | -270 to 1013°C -454 to 1855.4°F |
| | T | n/a | n/a | -170 to 400°C -274 to 752°F | ±0.25°C (±0.45°F) | -270 to 407°C -454 to 764.6°F |
| | R | n/a | n/a | 0 to 1760°C 32 to 3200°F | ±0.55°C (±0.99°F) | -50 to 1786°C -58 to 3246.8°F |
| | S | n/a | n/a | 0 to 1760°C 32 to 3200°F | ±0.55°C (±0.99°F) | -50 to 1786°C -58 to 3246.8°F |
| | B | n/a | n/a | 400 to 1820°C 752 to 3308°F | ±0.75°C (±1.35°F) | 200 to 1836°C 392 to 3336.8°F |
| | N | n/a | n/a | -130 to 1300°C -202 to 2372°F | ±0.40°C (±0.72°F) | -270 to 1316°C -454 to 2400.8°F |
| | C | n/a | n/a | 0 to 2300°C 32 to 4172°F | ±0.80°C (±1.44°F) | 0 to 2338°C 32 to 4240.4°F |
| mV | mV | n/a | n/a | n/a | ±30 microvolts | -50 to 1000mV |

Ordering Information

| Unit | Input | Output | Power | Options | Housing |
|--------------------------------------------------------------------------------------------------|--------------------------------------------------------------------------------------------------------------------------------------------------------------------------------------------------------------------------------------------------------------------------------------------------------------------------------------------------------------------------------------------------------------------------------------------------------------------------------------------------------|----------------------------------------------------|--------------------------|----------------------------------------------------------------------------------------------------------------------------------|--------------------------------------------------------------------------------------------------------------------------------------------------------------------------------------------------------------------------------------------------------------------------------------------------------------------------------------------------------------------------------|
| TMZ PC-Programmable MODBUS Temperature Transmitter and Signal Converter | Single Input Models: HLPRG Single input that programs to accept Current or Voltage Input Current input range: 0-50mA Voltage input range: 0-10Vdc TPRG Single input that programs to accept RTD, T/C, Ohms and mV Input (see Table 5 for details) Dual Universal Input Model: 2PRG Dual input where each input can be configured for <i>HLPRG</i> or <i>TPRG</i> input type (Using input selectors) | MB MODBUS RTU (RS-485) communications | 24DC (9-30Vdc) | -RF Enhanced RFI/EMI protection* (see "Specifications" for details) * Only applies to Single Input Models | DIN Universal DIN-style housing mounts on 32mm (EN50035) G-type and 35mm (EN50022) Top Hat DIN- rails (HLPRG and TPRG models only) 2PRG model only mounts on 35mm (EN50022) Top Hat DIN-rail FLB Externally- mounted flange provides a secure mount and ensures resistance to vibration |

When ordering, specify: Unit / Input / Output / Power / Options [Housing]

Model number example: TMZ / TPRG / MB / 24DC / -RF [DIN]

Accessories

Each TMZ order comes with one copy of our Windows Intelligent PC Configuration Software. Use the chart below to order additional parts.

| | |
|------------------------------------|----------------------------------------------------------------------------------------------|
| Part Number 750-75E05-01 | TMZ Intelligent PC Configuration Software (One copy provided free with each order) |
| Part Number 803-053-26 | Non-Isolated Serial Configuration Cable |
| Part Number 804-030-26 | Fuse Protected, Non-Isolated USB Communication Cable |

All product names are the trademarks of their respective companies.

Figure 7. TMZ Installation Dimensions for HLPRG and TPRG Models

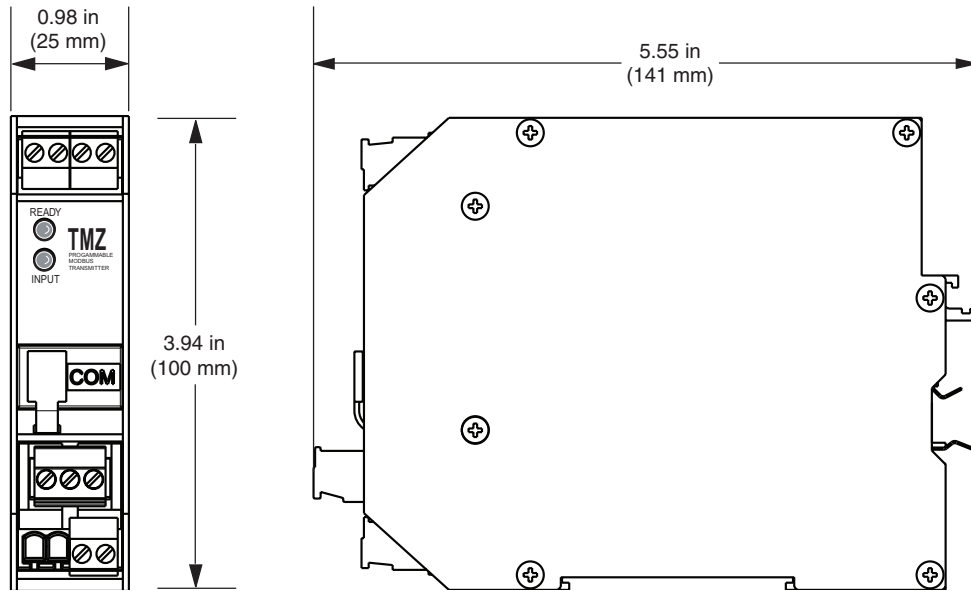

Figure 8. TMZ Installation Dimensions 2PRG Model

